

MICHAELANASTASSIADES

INSTALLATION INSTRUCTIONS



BLUE SKIES, 2023

PRODUCT SPECIFICATIONS

Input voltage: 120V / 240V
Maximum wattage: 10W

Provided with 2500mm cord set and dimmer switch.

Product weight: 4kg

IP 20: Indoor Use Only

BEFORE INSTALLING

Please keep these instructions for future reference. Please read instructions in full prior to installation noting all illustrations. Instructions should be followed precisely.

The fitting is for use in a normal dry domestic indoor environment.

If in any doubt about electrical safety, contact a qualified electrician.

Installation should always be carried out by a qualified electrician or a competent person in accordance with your current electrical regulation.

Please do not fit bulbs exceeding the maximum allowable wattage.

Ensure the circuit, to which the fixture is to be connected, has been installed and fused in accordance with your local electrical standards.

If the external flexible cable or cord is damaged, it should be replaced exclusively by MICHAEL ANASTASSIADES or a similar qualified person to avoid a hazard.

Ensure that only the correct types of bulbs are fitted.

If a bulb requires replacement, always switch off the mains power and allow the fixture to cool.

Position the fixture where desired, ensuring that the area is suitable to support the weight of the fixture.

Modifying any part of the fixture will void the products warranty.

MICHAEL ANASTASSIADES takes no responsibility for incorrectly installed lights.

CLEANING INSTRUCTIONS

Before cleaning, lighting fixtures must be turned off and unplugged from mains electricity. Whilst cleaning please take care and use the gloves provided.

Polished Nickel-Plated Brass: Use a lightly damp soft dust cloth and gently go over marks until clean. Dry it afterwards with a soft dust cloth. Make sure the product is completely dry before switching the electricity on.

Hinoki Wood: Use a soft dust cloth and gently go over marks until clean.

Tosa Washi Paper: Gently dust with a soft dry cloth or brush. Do not use liquids, detergents and/or damp cloths.

PAPER MAINTENANCE

The lampshade is made in Japan, with the craftsmanship of local artisans. The meticulous execution obtained through traditional methods, handed down through generations, gives the product lightness and poetry. Tosa washi paper fibres are hand-processed, layered, pressed, dried, and dipped into Konnyaku liquid to form a thin and durable sheet. The disc is then precisely cut to size around the handmade Hinoki Wood disk.

The product must be handled with care, given its delicate nature, avoiding making impacts or applying excessive force to the paper, as this can lead to damage, wrinkles and breakage. It is for indoor use only and to preserve its appearance, we advise keeping it away from direct sunlight, as well as excessively dry or humid environments. Humidity can cause sagging and wrinkles. Over time, with exposure to light, washi paper will undergo discolouration, such as yellowing, dullness, or bleaching. Please keep away from fire.

In the development process, the lampshade underwent an environmental test to establish the potential weather conditions damage. The result states that, after 48 hours of increased humidity at 90%, and 48 hours of decreased humidity at 30%, warpage of a maximum of 6 mm can occur on the disc, and that some minor peeling can appear between the paper and the wood ring.

Parts Supplied

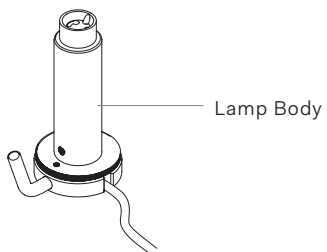
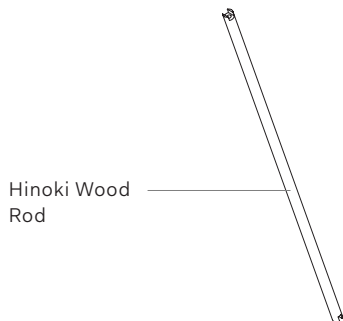
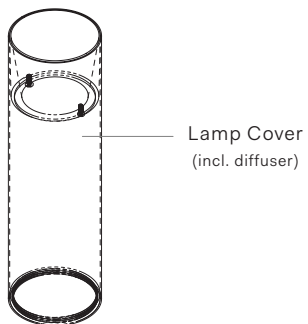
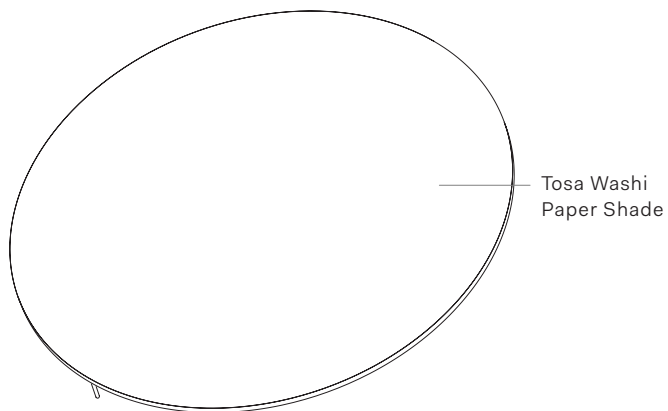

Additional Items Provided

Pair of Gloves
GU10 Bulb

INSTALLATION PREPARATION

Whilst installing the fixture, please take care and use the gloves provided.

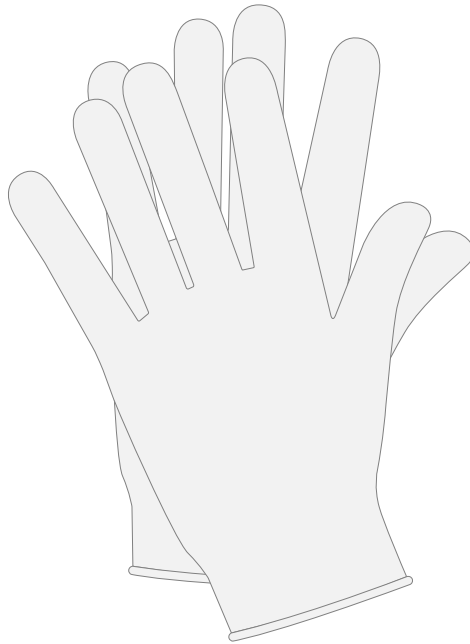

Fig. 1

Prepare the Lamp Body and cable for assembly.

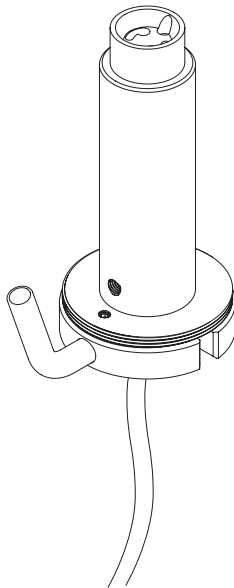

Fig. 2

Turn the lamp body upside-down and pull the cable along the slot in the direction of your choice.
The direction that the cable exits affects the route of the cable.

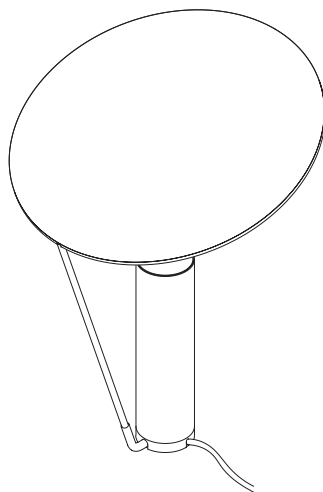
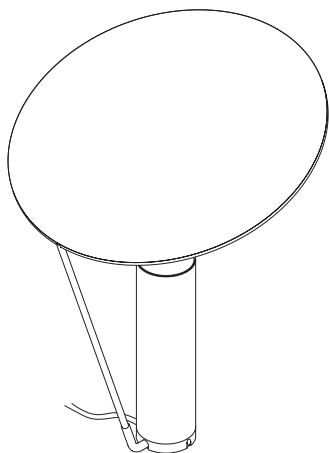
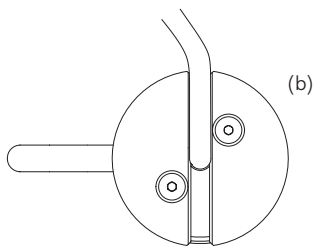
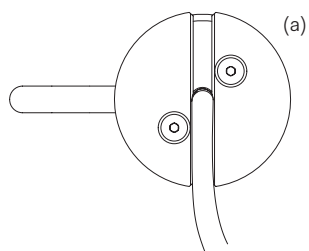

Fig. 3

Place the Ring (A) on to the Lamp Body, Ensuring the slots line up with the cable and the Supporting Arm (B).

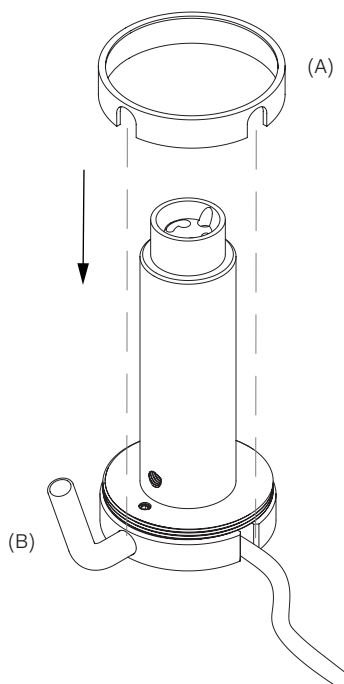

Fig. 4

Insert the bulb.

Ensure the pins of the bulb line up with the corresponding holes of the lampholder.

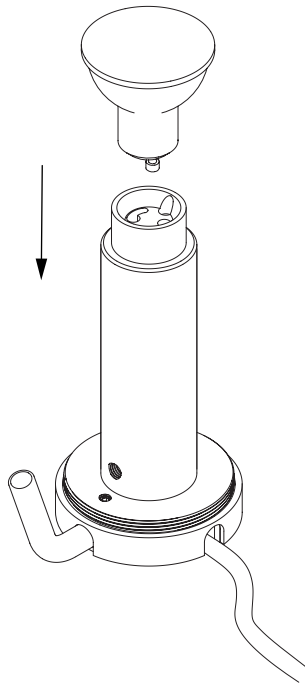

Fig. 5

Place the Diffuser Body (C) over the bulb and Lamp Body and turn clockwise to secure.

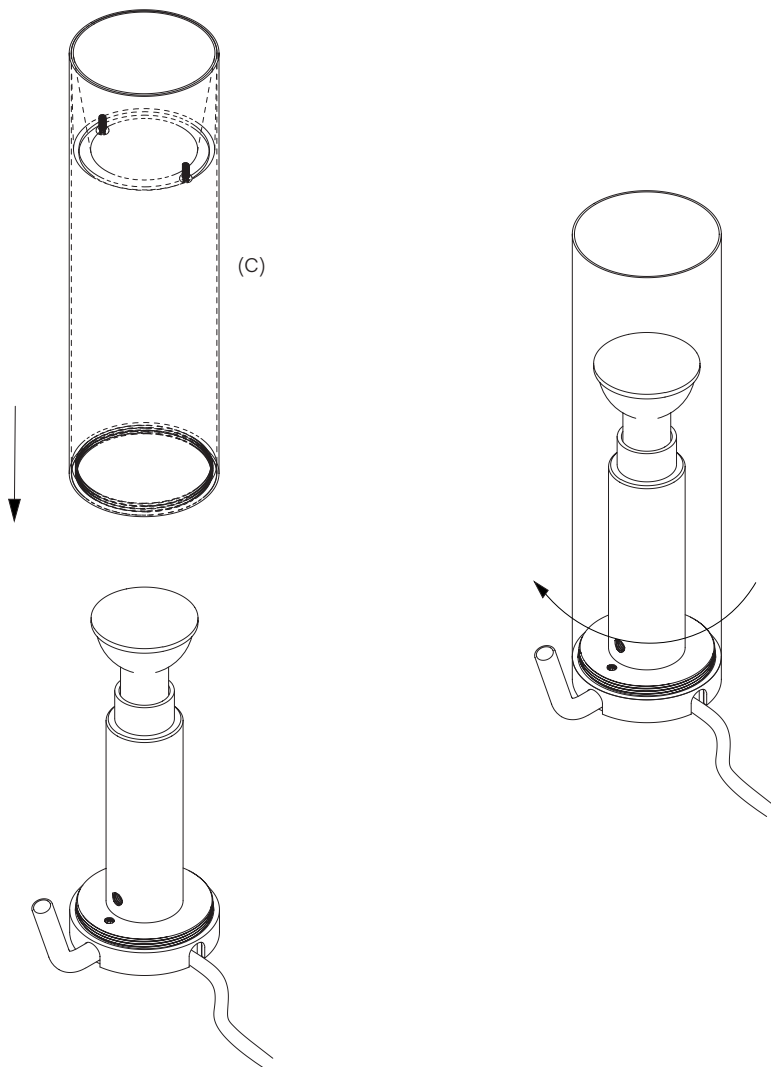

Fig. 6

Identify the top and bottom of the Rod (D).

Locate the Orientation screws and their positioning inside the Support Arm.

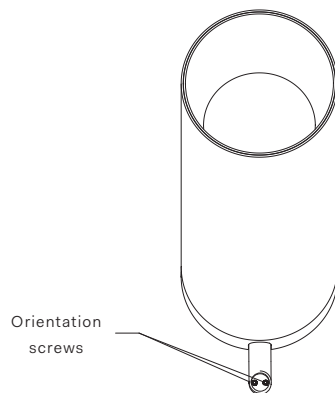
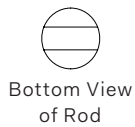

Fig. 7

Place the Rod into the Support Arm (B).
Ensure that the bottom of the rod enters the Support Arm and that the slot correctly lines up with the orientation screws inside the Support Arm.
When inserted correctly, the rod should not be able to rotate.

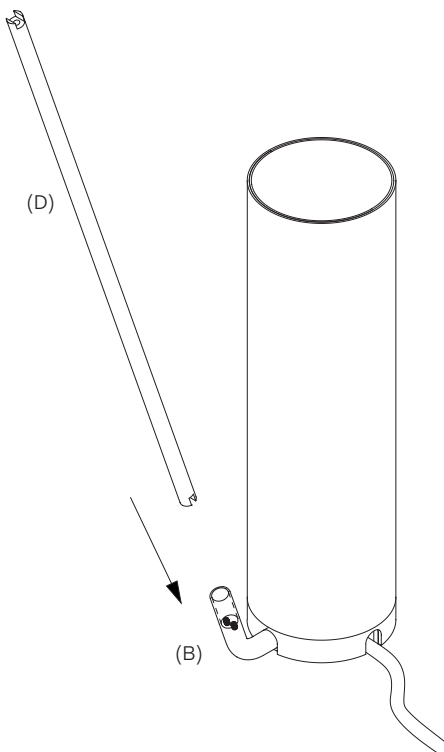

Fig. 8

Insert the Shade pin (E) into the Rod (C).

Ensure the rim of the Shade is seated in the slot at the top of the Rod.

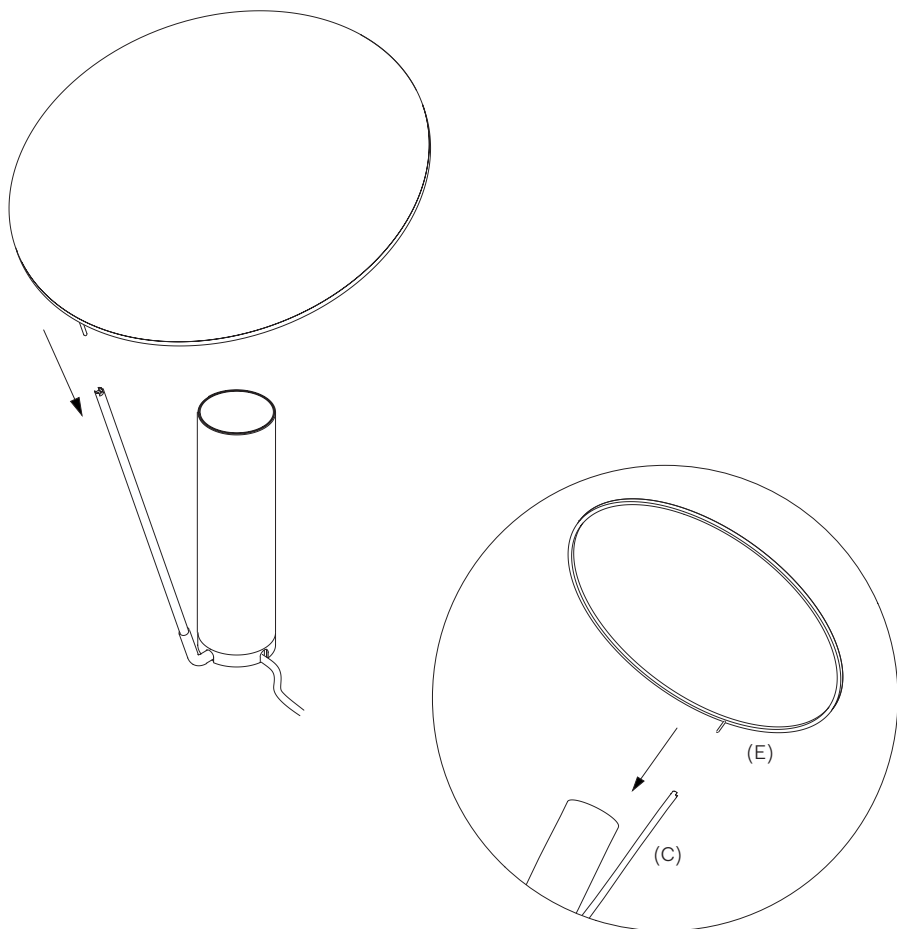
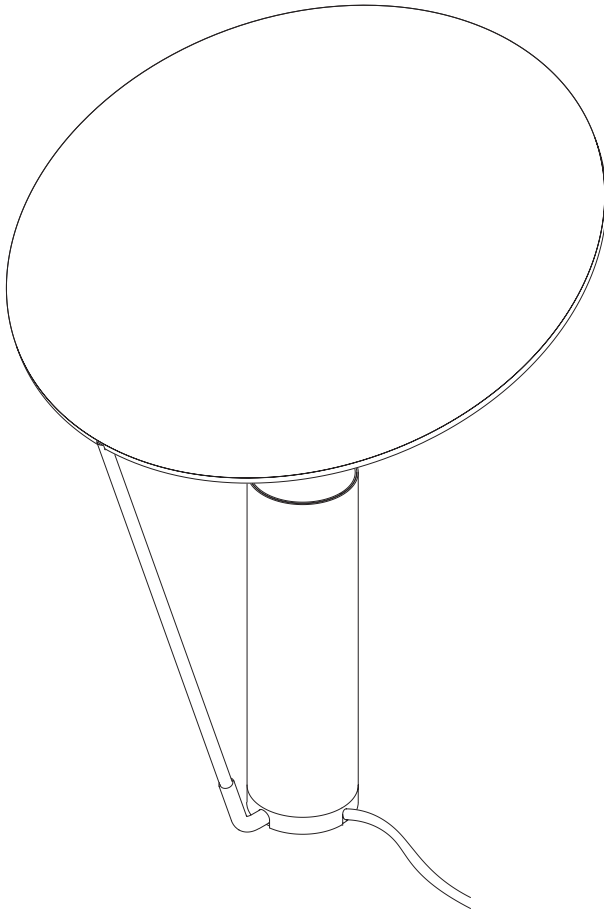

Fig. 9

Your lamp is now complete.



Michael Anastassiades' design philosophy is to preserve the inherent qualities of given materials. All of our products are handmade and come in natural finishes, exposed to the elements without any protective lacquers. We look at oxidisation as part of a process that adds to the patina of an object, increasing beauty with time. We try our best for all goods to leave our premises in pristine condition, but sometimes products may arrive with minor oxidisation marks.

Whilst every effort is made to ensure an accurate representation of product colours, finishes and dimensions, Michael Anastassiades Ltd reserves the right to alter these details without notice, in compliance with its own production needs, technological changes or in response to the current market needs. Colour swatches are for reference only; Michael Anastassiades Ltd cannot guarantee exact colour match for any product finishes.

All designs are protected under copyright law. Michael Anastassiades holds the exclusive manufacturing and distribution rights worldwide. Copying will be prosecuted.

All light fixtures in this catalogue have CE marking compliance.

Michael Anastassiades Ltd.
50 Rochester Place, London NW1 9JX
T +44 (0)20 7928 7527
sales@michaelanastassiades.com
www.michaelanastassiades.com
© 2024 Michael Anastassiades Ltd. All rights reserved.